

PRESSOSTATO MONOFASE MODELLO MIGNON THERM

MONOPHASE PRESSURE SWITCH TYPE MIGNON THERM



Dati tecnici :

Technical details :

20 Amp. max. , 50/60 Hz. 220 Volt max

20 Amp. max, 50/60 Hz. 220 Volt max.

Pressione massima di esercizio : 9 / 12 / 15 bar

Max pressure working : 9 / 12 / 15 bar

Valvola di scarico testata disponibile nei seguenti modelli :

VNP : plastica, innesto rapido tubo rilsan diametro 6mm. normalmente chiusa;

VRP : plastica,innesto rapido tubo rilsan diametro 6mm.ritardata con chiusura a 1.2 bar;

VRPBLU: plastica,innesto rapido tubo rilsan diametro 6 mm.ritardata con chiusura a 1.8 bar;

VNO : ottone, chiusura a ogiva per tubo diametro 6 mm. normalmente chiusa;

VRO : ottone, chiusura a ogiva per tubo rilsan diametro 6mm. ritardata con chiusura a 1.2 bar

VNO/VROTW: ottone, chiusura a ogiva per tubo rame diametro 6.5mm. normalmente chiusa/ ritardata.

M280TNB-1/M280TRBB-1:Ottone,chiusura a ogiva per tubo diametro 6 mm. con silenziatore normalmente chiusa/ritardata ;

E25/1PLM:innesto rapido 90°per tubo rilsan diametro 6

Unloader valves available in the following models :

VNP: plastic, normal closed valve for rilsan tube 6 mm. diameter ;

VRP: plastic, delayed valve with closing at 1.2 bar for rilsan tube 6 mm. diameter;

VRPBLU:plastic, delayed valve with closing at 2.2 bar for for rilsan tube 6 mm. diameter;

VNO : brass valve, normal closed for brass or rilsan tube 6 mm. diameter;

VRO : brass valve, delayed closing valve at 1.2 bar for brass or rilsan tube 6 mm. diameter;

VNO/VROTW : brass valve , normal closing or delayed for brass tube 6.5 mm. diameter.

M28N-1 / M28 TRBB-1: Brass closure copper pipe diameter 6 mm. with silencer normally closed / delayed;

E25 / 1 PLM: quick coupling 90 ° for Rilsan tube diameters 6

Attenzione : Temperatura di esercizio 0°C- 50°C. A temperature differenti e con lunghi periodi di mancato utilizzo si possono verificare , nelle prime fasi di lavoro, comportamenti differenti dai valori di collaudo e conseguenti interventi delle valvole di sicurezza. Temperature superiori a quanto indicato possono provocare deformazioni delle plastiche

Warning : Working temperature 0°C. 50°C. With different temperature conditions and after long period of non -use some differences in setting can occur caused safely valve action. Higher temperature can cause deformations of plastic materials.

Attenzione : max. temperatura aria su membrana standard max. 90°C.

Warning : max. air temperature on standard membrane max. 90°C.

a richiesta : membrana in silicone max. temperatura 140 °C.
on request : silicon membrane temperature max. 140°C.

Schema connessioni elettriche :

Electrical connections :

I collegamenti elettrici vanno eseguite da personale qualificato.

Only qualified staff can connect this device.

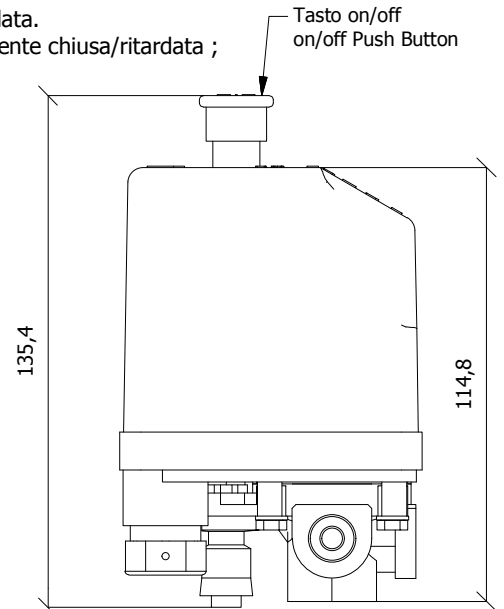
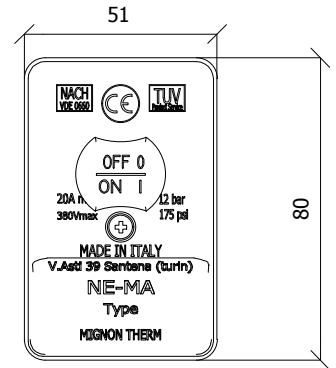
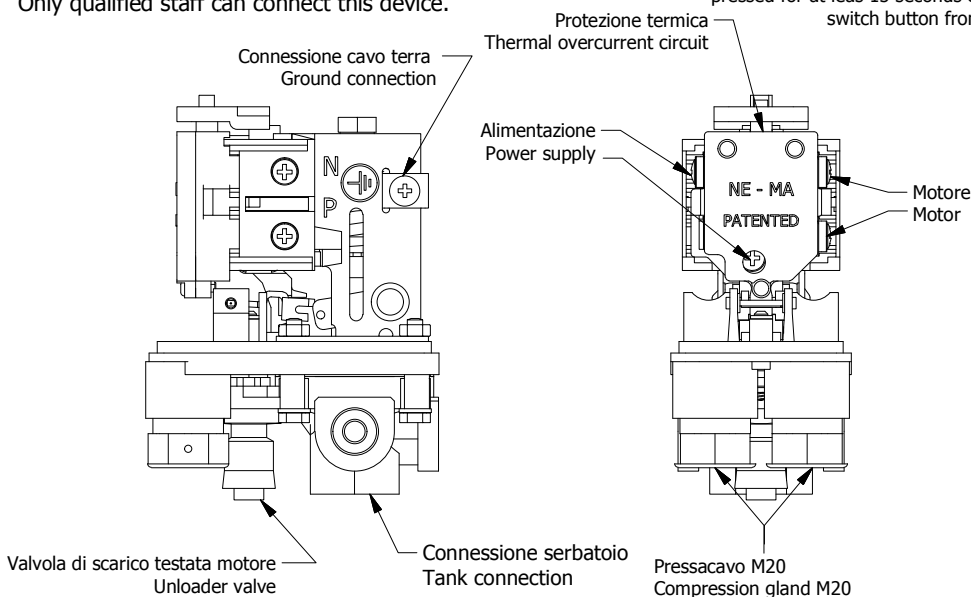

Certificazioni di prodotto / Product Certifications

Apparecchio dotato di protezione termica incorporata in caso di intervento agire esclusivamente sul pulsante del pressostato premendo in posizione "OFF" dopo almeno 15 secondi, portarlo in posizione "ON" per il regolare avvio

In this pressure switch a thermal overcurrent circuit breaker is assembled, in order to reset the device, keep pressed for at least 15 seconds exclusively the pressure switch button from "OFF" to "ON" position



VNO/VRO/TW

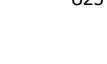
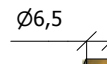

M280TNB-1 / M280TRB-1



E25/1PLM



Regolazioni del pressostato / Réglage Pressostat : Regulierung Druckwaechter / Pressure switch setting :

2 Ghiera di regolazione "delta p" * optional
Nut to set " delta p" * optional

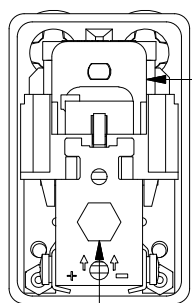

Termiche disponibili da 1 a 20 Amp
Thermal overcurrent circuit available from 1 to 20 Amp.

1 Vite di regolazione Ch.10
Regulation screw Ch.10

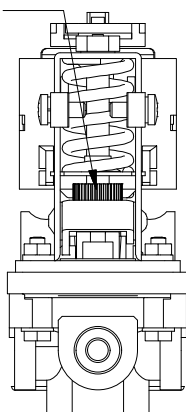

Cut in pressure
P1=6/4
P2=12/10

Regolazione del pressostato:

Per aumentare la pressione , ruotate la vite esagonale Ch 10 (1) posta sull'estremità superiore del pressostato in senso orario. Per diminuire, girare in senso antiorario.

Regolazione del differenziale :

Per aumentare il differenziale ruotare verso destra la ranella dentata posta sotto la molla (2) .

ATTENZIONE : le operazioni vanno eseguite con pressostato in pressione.

Il pressostato , se non richiesto, è regolato sul differenziale minimo.

Pressure switch setting:

To increase pressure, turn the hexagon Ch 10 (1) on the top of pressure switch clockwise.

To reduce the pressure, turn it anticlockwise.

"Delta p" setting :

To increase the difference between cut in and cut out, turn the toothed wheel situated under the spring to the right using a screwdriver(2).

Warning : these operations must always be performed with the pressure switch under pression.

The pressure switch, if there is no different indication, is on the minimum point.

Regulierung Druckwaechter

Druckregulierung : um den druck zu erhoehen, das Sechskant von Ch 10(1), welches sich am oberen ende des druckwaechters befindet, im Uhrzeigersinn drehen. Um den druck zu wermindern, in Gegenrichtung der uhrdrehen.

Regulierung der unterbrechungsdauer (Abstaende) : Um die pausen zu verlaengern, die ausgezackte dichtungsscheibe , welche sich unter der grossen feder befindet, mittels einem schraubenzieher nach rechts drehen(2).

Achtung : bei der ausfuehrung dieser handlungen muss sich der druckwaechter immer druck befinden.

Der druckwaechter in seiner gegenwaertigen position ist bereits auf mindestpausen eingestellt.

Réglage Pressostat

Réglage Pression : pour augmenter la pression, tourner l'exagone de Ch 10 (1) placé à l'extrémité supérieure du pressostat dans le sens des aiguilles d'une montre. Pour diminuer la pression, tourner en sens contraire.

Réglage " delta p" : pour augmneter l'intervalle, tourner vers la droite la rondelle dentelée placée sous le gros ressort au moyen d'un tournevis.

Attention : cette opération doit toujours être effectuée avec le pressostat sous pression.

Le pressostat étant dans la position actuelle réglé à son minimum d'intervalle.

Type PM12TH CODICE PM12TH

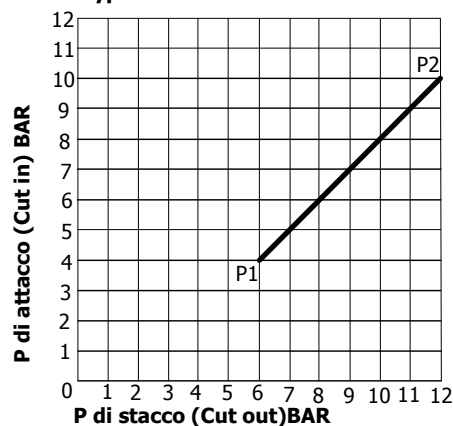

Type PMR12TH CODICE PMR12TH

*Type PMR20TH HIGH PRESSURE
*Codice PMR20TH ALTA PRESSIONE

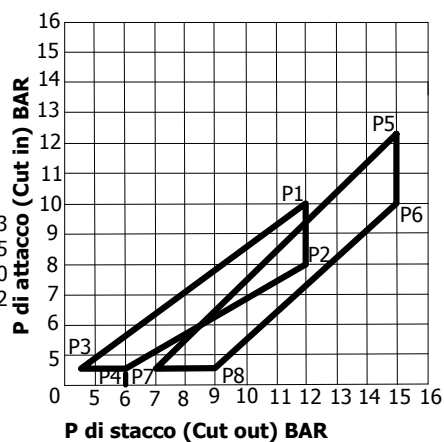

Cut in pressure
P1=6/4
P2=12/9,5
P3=6,5/4
P4=12/10
*P5=10-13
*P6=12-15
*P7=13-10
*P8=15-12

Type PMACQTH CODICE PMACQTH

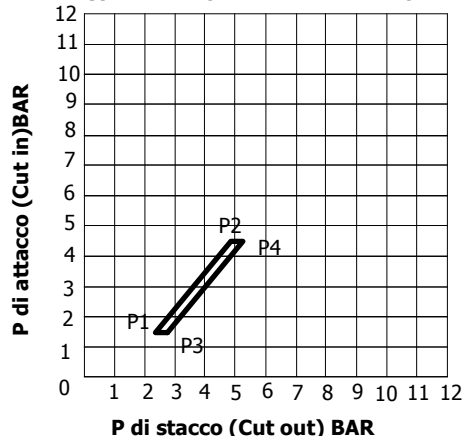

Cut in pressure
High Sensibility
P1=2.5/1.5
P2=5.5/4.5
Normal Sensibility (Standard)
P3=2.8/1.4
P4=6/4.6

Type PMRACQTH CODICE PMRACQTH

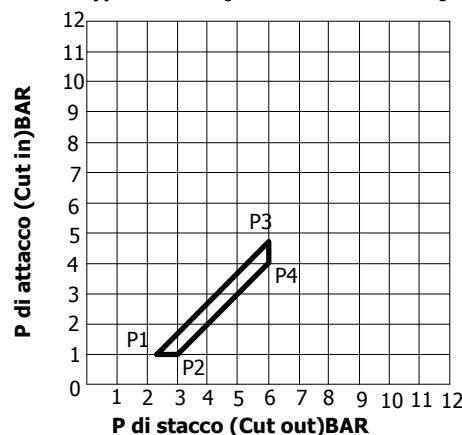

Cut in pressure
P1=2.2/1.2
P2=3.2/1.2
P3=6/4.8
P4=6/4